

On the Issue of Argumentation and Informedness

Martin Caminada¹ and Chiaki Sakama²

¹ Cardiff University

CaminadaM@cardiff.ac.uk

² Wakayama University

sakama@sys.wakayama-u.ac.jp

Abstract. In the current paper we examine how to assess knowledge and expertise in an argumentation based setting. In particular, we are looking for a formal criterion to determine whether one agent is more knowledgeable than another. Several such criteria are discussed, each of which has its own advantages and disadvantages.

1 Introduction

Formal argumentation theory has been applied to study a whole range of different questions, like “what to accept” [12], “how to come to a joint position” [9] and “how much do different positions differ” [4]. In the current document, we will study a similar question, which can be summarized as “who knows more”.

In the context of nonmonotonic reasoning, determining who knows more is far from trivial. Although there are some studies that formulate comparison among nonmonotonic theories ([14, 20] for instance), one cannot say that one (nonmonotonic) theory is more informative than another one by simply comparing the sets of entailed conclusions. After all, the fact that the set of entailed conclusions of one agent is bigger than (a superset of) the set of entailed conclusions of the other agent might be due to the fact that the latter agent has information that invalidates one of the inferences made by the first agent. In this case, it would not seem reasonable to claim that the former agent has more knowledge (or is better informed) than the second agent.

Another approach would be to compare not the sets of entailed conclusions, but instead to compare the contents of the knowledge bases. This, however, leads to problems like what to do when two knowledge bases are syntactically different but semantically equivalent. Furthermore, it could very well be that an agent has information that another agent knows to be inapplicable (say, reading a newspaper that another agent knows to be unreliable). Therefore, measuring the raw contents of the knowledge bases is not necessarily appropriate to determine which agent knows more.

Yet, the issue of coming up with a suitable criterion for determining who knows more is an important one. If the aim is for instance to hire an expert or consultant to make a decision, how does one *assure* that the person in question

actually possesses expertise? Or, on a more basic level, how even to *define* expertise or determine how expertise or knowledge of an agent matches up to that of another agent?

In the existing literature on formal logic, issues of reasoning about knowledge (epistemic reasoning) have traditionally been studied using modal logic, in particular by applying modalities that satisfy the KD45 or KT45 axiomatizations. The problem, however, is that where conceptually knowledge stands for “justified true belief”, the KD45 and KT45 axiomatization simplify the concept of knowledge to “true belief” since it does not offer the facilities to model the concept of justification. Simplifying the concept of knowledge to “belief that happens to be true” can lead to debatable outcomes, since a lay person who on a particular topic is merely right by accident would be considered to have knowledge, whereas an expert who is wrong due to exceptional and unforeseen circumstances would be considered to have no knowledge. Apart from that, in many cases one cannot simply as an outsider determine whose beliefs are true and whose are not. If two experts disagree about, say, forecasts of climate change, then one cannot simply determine who of them is right (has beliefs that are true) although one might still want to have some idea about who of these experts is better informed. From practical perspective, the concept of “justified belief” is often as more important than that of “true belief”.

If one is to take the concept of justified belief seriously, then one is to apply a formal approach that is based not so much on truth (as is the case in modal logic, which essentially models knowledge as true belief) but on justification. The next question then becomes how one could characterize a formal notion of justification, without applying the notion of truth. One possibility would be to interpret justified belief as that which can be defended in rational discussion. In formal argumentation theory, several forms of rational discussion (and the associated argumentation semantics) have been identified. Abstract argumentation theory under grounded semantics, for instance, can be seen as corresponding to persuasion discussion, whereas abstract argumentation theory under (credulous) preferred semantics can be seen as corresponding to Socratic discussion [7].

Furthermore, if one agrees that nonmonotonic aspects are at the heart of many real world reasoning processes, then it makes sense to apply a formalism that is able to deal with nonmonotonicity. Abstract argumentation theory is one of the simplest and most straightforward approaches to nonmonotonic reasoning and has nevertheless been shown to capture a wide range of full-blown nonmonotonic logics [12, 16, 19, 23]. Hence, it makes sense to apply argumentation theory as a starting point for examining the concept of “justified belief”, which we will sometimes refer to as “informedness” (to distinguish it from “knowledge”, which in the mainstream literature on epistemic logic has come to mean “true belief”).

The remaining part of this document is structured as follows. First, in Section 2 we briefly summarize some of the key notions in (abstract) argumentation theory. Then, in Section 3, we examine several candidate criteria for evaluating relative informedness. We round off in Section 4 with a discussion and some issues for further research.

2 Abstract Argumentation Theory

In the current section, we provide a brief overview of some basic notions in abstract argumentation theory. We will focus on the notions that we actually need for examining the concept of argument-based informedness in the next section, and refer to [1] for a more elaborate treatment.

Definition 1. *An argumentation framework is a pair (Ar, att) in which Ar is a (finite) set of arguments, and $att \subseteq Ar \times Ar$.*

Since an argumentation framework is in essence a (finite) graph, we often use a graphical representation of it. Although various approaches (such as [12, 23, 6, 18, 21]) have been formulated where arguments do have an internal structure (usually in the form of defeasible derivations), in the current document we will leave the internal structure completely abstract. That is, we will treat argumentation theory at the highest level of abstraction. As for notation, for argumentation frameworks $AF_1 = (Ar_1, att_1)$ and $AF_2 = (Ar_2, att_2)$, we write $AF_1 \sqsubseteq AF_2$ to indicate that $Ar_1 \subseteq Ar_2$ and $att_1 = att_2 \cap (Ar_1 \times Ar_1)$.

The next question becomes what are the reasonable positions one might take based on the conflicting information in the argumentation framework. In the current document, we will apply the approach of *argument labellings* [5, 8] for expressing these positions.

Definition 2. *Let (Ar, att) be an argumentation framework. An argument labelling is a (total) function $Lab : Ar \rightarrow \{\text{in}, \text{out}, \text{undec}\}$.*

An argument labelling can be seen as a position on which arguments should be accepted (labelled **in**), which arguments should be rejected (labelled **out**) and which arguments should be abstained from having an explicit opinion about (labelled **undec**).

Although argument labellings allow one to express any arbitrary opinion, some opinions can be regarded to be more reasonable than others. When precisely a position can be considered to be reasonable is formally defined by *argumentation semantics*.

Definition 3. *Let Lab be a labelling of argumentation framework (Ar, att) . Lab is said to be an admissible labelling iff for each argument $A \in Ar$ it holds that:*

- if $Lab(A) = \text{in}$ then for each $B \in Ar$ such that $B \text{ att } A$ it holds that $Lab(B) = \text{out}$
- if $Lab(A) = \text{out}$ then there exists a $B \in Ar$ such that $B \text{ att } A$ and $Lab(B) = \text{in}$

An admissible labelling is called complete iff it also satisfies:

- if $Lab(A) = \text{undec}$ then it is not the case that for each $B \in Ar$ such that $B \text{ att } A$ it holds that $Lab(B) = \text{out}$, and it is not the case that there exists a $B \in Ar$ such that $B \text{ att } A$ and $Lab(B) = \text{in}$

Hence, the idea of an admissible labelling is that one should have sufficient grounds for everything one accepts (because all attackers are rejected) and sufficient grounds for everything one rejects (because it has an attacker that is accepted). A trivial way to satisfy this would be to take an extreme sceptical approach (simply label each argument **undec**). Therefore, the concept of a complete labelling has the additional requirement on whether one is allowed to abstain from having an explicit opinion on an argument (label it **undec**). One is only allowed to do so if one has insufficient grounds for accepting it (not all its attackers are rejected) and insufficient grounds for rejecting it (there is no attacker that is accepted).

Based on the concept of a complete labelling, it then becomes possible to define various other argumentation semantics (see [1] for an overview). Furthermore, we have to mention that the labelling approach is equivalent with the traditional extensions approach proposed in [12] (see [5, 8] for details).

3 Argument-Based Informedness

We assume the presence of a UAF, a “universal argumentation framework”, that serves as the universe of all valid arguments. Each individual agent is assumed to have access only to part of the world, therefore the private argumentation framework AF_i of agent i is assumed to be a subgraph of the UAF. Furthermore, if an agent has two arguments at his disposal, then he agrees with the UAF whether one attacks the other. This is in line with the approach of instantiated argumentation [6, 21, 18, 3] where one knows the internal structure of the arguments and can therefore assess whether they attack each other or not.³

Formally, the situation can be described as follows. There exists a $UAF = (Ar_{UAF}, att_{UAF})$, together with n agents ($n \geq 1$), each of which knows only a subset $Ar_i \subseteq Ar_{UAF}$ of arguments and hence has an argumentation framework $AF_i = (Ar_i, att_{UAF} \cap (Ar_i \times Ar_i))$. That is, $AF_i \sqsubseteq UAF$.

The question we would like to study is “which agent knows more?” Of course, an easy way to define this would be to use the subgraph relation. That is, agent j knows at least as much as agent i iff $AF_i \sqsubseteq AF_j$ (which in this case simply means that $Ar_i \subseteq Ar_j$). The problem, however, is that for many practical purposes, this characterisation is too strong. If each agent has some private information (like observations that nobody else was able to make) then he will have arguments that are not shared by anybody else. Hence, the resulting partial order will be the empty one, making all agents incomparable.

It does, however, seem reasonable to try to define the “more or equally informed” relation in such a way that an agent with an argumentation framework that is a supergraph of that of another agent is automatically more or equally

³ In terms of instantiated argumentation [6, 21, 18, 3], the UAF consists of the arguments that can be constructed from all the available information in the world (from the “universal knowledge base”). Each agent’s private argumentation framework then consists of the arguments that can be constructed from his private knowledge base.

informed. Furthermore, the expression “more or equally informed” seems to suggest at least a partial pre-order. That is, what we are interested in is a relation \preceq that satisfies at least the following properties, for each $i, j, k \in \{1, \dots, n\}$:

1. if $AF_i \sqsubseteq AF_j$ then $AF_i \preceq AF_j$ (refinement of sub-AF relation)
2. $AF_i \preceq AF_i$ (reflexivity)
3. if $AF_i \preceq AF_j$ and $AF_j \preceq AF_k$ then $AF_i \preceq AF_k$ (transitivity)

Defining a suitable notion of informedness is far from trivial, because one needs to satisfy not only the above stated properties, but also needs to handle a number of examples in a reasonable way that does not deviate too much from what most people’s intuitions would be.

To obtain an idea of what the difficulties are, we will now discuss three possible candidates for defining the “more or equally informed” relation. In each of these relations, we focus on a single argument. This is because we believe that different agents can have different competences. One agent may be more informed about, say, climate change and the other more about financial markets. The overall knowledge of two experts may be incomparable, but on different topics (or on different particular arguments) it still seems fair to say that one is better informed than the other.

3.1 Informedness based on upstream

The first possible criterion is comparing what we call the “upstream” of a particular argument, which consists of all ancestor arguments in a particular argumentation framework. This approach makes sense also because several of the mainstream argumentation semantics, like complete, preferred and grounded, satisfy the principle of *directionality* [2], meaning that for determining the justification status of an argument [22, 13] only the upstream is relevant.

Definition 4. Let $AF = (Ar, att)$ be an argumentation framework and $A \in Ar$. We define $upstream_{AF}(A)$ as the smallest set such that:

- $A \in upstream_{AF}(A)$, and
- if $X \in upstream_{AF}(A)$ and Y attacks X then $Y \in upstream_{AF}(A)$

We define a relation \preceq_{us}^A (informedness based on upstream) such that if AF_i and AF_j are subframeworks of the UAF, then $AF_i \preceq_{us}^A AF_j$ iff $upstream_{AF_i}(A) \subseteq upstream_{AF_j}(A)$.

The thus defined notion of informedness, based on upstream, satisfies properties 1, 2 and 3. It satisfies property 1 because a supergraph always has an upstream that is a superset, for any argument. It satisfies properties 2 and 3 because the subset relationship is a partial pre-order.

In spite of these nice formal properties, the upstream-based notion of informedness also has some difficulties, as are for instance illustrated in the situation depicted in Figure 1.

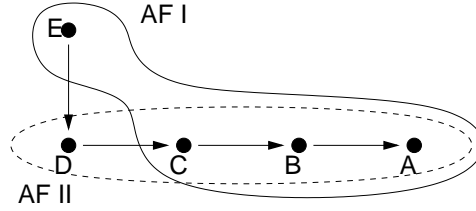

Fig. 1. AF_{II} more informed than AF_I according to the upstream criterion.

In the situation depicted in Figure 1, we have agent I who knows about arguments A , B , C and E , and agent II who knows about arguments A , B , C and D . We have that $upstream_{AF_I}(A) = \{A, B, C\}$ and $upstream_{AF_{II}}(A) = \{A, B, C, D\}$. Therefore, $AF_I \preceq_{us}^A AF_{II}$. However, one may argue that it is actually agent I who should be more informed, because if one would merge the argumentation frameworks ($AF_I \sqcup AF_{II}$) then agent I would be right about the status of A (“ A has to be in”) whereas the position of agent II (“ A has to be out”) would be wrong.

Furthermore, D could be an argument of which agent I immediately knows it doesn’t hold. Suppose D is the argument that “Barack Obama was not born in the USA because Bill O’Reilly says so on the Fox News Channel”. Agent I, however, knows from various studies that Bill O’Reilly and Fox news are not reliable sources of information, even though he doesn’t watch Fox himself, and therefore wasn’t even aware of the existence of argument D . However, as soon as agent I learns about the existence of argument D , he is immediately able to construct a counterargument against it (Fox is unreliable, therefore the fact that it claims something doesn’t necessarily imply that it’s also true). Here, it seems fair to say that it is agent I that is more informed than agent II, which is precisely the opposite as would follow from the upstream criterion.

3.2 Informedness based on merging the argumentation frameworks

If defining informedness based on upstream is troublesome, then perhaps one should seek for an alternative criterion. The next possibility to be discussed is to define informedness based on whose position would be supported if both agents would share their arguments.

For the definition below, we recall that the *justification status* [22] of an argument consists of the different labels the argument can be assigned to under a particular semantics (for current purposes, we apply complete semantics). For instance, $JS(A) = \{\text{in}, \text{undec}\}$ means there is a complete labelling that labels A in, there is a complete labelling that labels A undec, but there is no complete labelling that labels A out. See [22] for details.

Furthermore, if $AF_i = (Ar_i, att_i)$ and $AF_j = (Ar_j, att_j)$ are the argumentation frameworks of agent i and agent j , respectively, then we write $AF_i \sqcup AF_j$ to

denote the argumentation framework $(Ar_i \cup Ar_j, att_{UAF} \cap ((Ar_i \cup Ar_j) \times (Ar_i \cup Ar_j)))$.

Definition 5. Let AF_1, \dots, AF_n ($n \geq 1$) be subargumentation frameworks of the UAF, where for each AF_i ($1 \leq i \leq n$) it holds that $AF_i = (Ar_i, att_i)$. We define a relation \preceq_{ms}^A (informedness based on merged status) such that $AF_i \preceq_{ms}^A AF_j$ iff $A \in Ar_i \cap Ar_j$ and

- $JS_{AF_i}(A) \neq JS_{AF_j}(A)$ and $JS_{AF_i \sqcup AF_j}(A) = JS_{AF_j}(A)$, or
- $JS_{AF_i}(A) = JS_{AF_j}(A)$ and for each AF_k ($1 \leq k \leq n$) it holds that if $JS_{AF_i \sqcup AF_k}(A) = JS_{AF_i}(A)$ then $JS_{AF_j \sqcup AF_k}(A) = JS_{AF_j}(A)$

The idea of the above definition is as follows. If two agents *disagree* about the justification status of argument A , then one looks at which of their positions would be supported if both agents would share all their information (that is, we look at which position would be supported in $AF_i \sqcup AF_j$). If, however, the two agents *agree* on the justification status of argument A , then one looks at who would be best capable of defending this shared position. For instance, the average newspaper reader may have the same position on whether climate change is going to happen as an expert, but still one would be tempted to say that the expert knows more, because he is better capable of defending his position against criticism. The above definition basically says that if two agents i and j have the same opinion, and for every agent k it holds that if i can convince k then j can also convince k then j is at least as informed as i .

The above definition, although intuitively defensible, does have some undesirable technical properties. Although it satisfies reflexivity, it violates transitivity, as is illustrated in Figure 2.

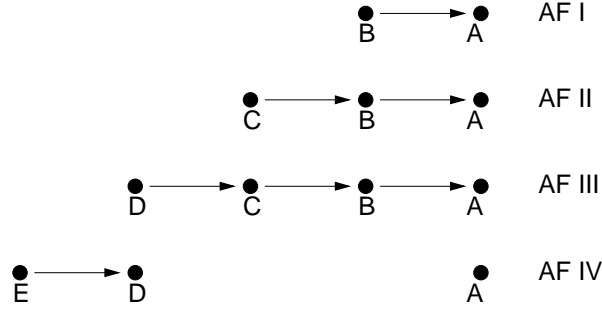

Fig. 2. Informedness based on merged status can violate transitivity

In the example depicted in Figure 2 we have that AF_I and AF_{III} disagree about the status of A : $JS_{AF_I}(A) = \{\text{out}\}$ and $JS_{AF_{III}}(A) = \{\text{in}\}$. However, if one were to merge AF_I and AF_{III} then the result would be the same as AF_{III} .

That is, $JS_{AF_I \sqcup AF_{II}}(A) = \{\text{in}\}$. Hence, $AF_I \preceq_{ms}^A AF_{II}$. For similar reasons, it also holds that $AF_{II} \prec_{ms}^A AF_{III}$. Transitivity would then require that we also have that $AF_I \preceq_{ms}^A AF_{III}$. However, this is not the case since whereas agent I can maintain his position on A when confronted with agent IV, agent III cannot maintain his position on A when confronted with agent IV. Therefore, $AF_I \not\preceq_{ms}^A AF_{III}$, so transitivity does not hold.⁴

It can be observed that property 1 (sub-AF refinement) also does not hold. In the example depicted in Figure 3. Here, it holds that $AF_I \sqsubseteq AF_{II}$. However, it does *not* hold that $AF_I \preceq_{ms}^A AF_{II}$ because whereas agent I can maintain his position on A when confronted with agent III, agent II cannot.

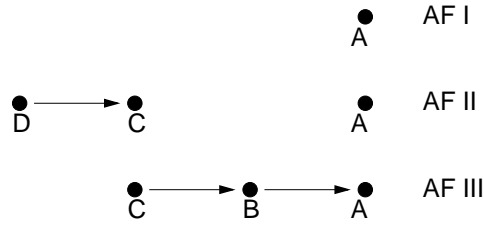

Fig. 3. Informedness based on merged status can violate the sub-AF property

There seems to be no easy way of patching up the definition of \preceq_{ms}^A . Omitting the second condition (when $JS_{AF_i}(A) = JS_{AF_j}(A)$) does not help, because it would mean that while $(A) \sqsubseteq (C \rightarrow B \rightarrow A)$ ⁵ it does not hold that $(A) \preceq_{ms}^A (C \rightarrow B \rightarrow A)$, hence violating condition 1 (sub-AF refinement). Trivialising the second condition (saying that $AF_i \preceq_{ms}^A AF_j$ and $AF_j \preceq_{ms}^A AF_i$ whenever AF_i and AF_j agree on the status of A) does not work either, since this would imply that $(C \rightarrow B \rightarrow A) \preceq_{ms}^A (A) \preceq_{ms}^A (B \rightarrow A)$ whereas $(C \rightarrow B \rightarrow A) \not\preceq_{ms}^A (B \rightarrow A)$, thus violating transitivity.

3.3 Informedness based on discussions using private knowledge

A third possible approach would be to define informedness in a dialectical way. If two agents disagree about the status of a particular argument, then let them

⁴ The fact that transitivity does not hold can be problematic for applications of the theory. For instance, when the aim is for an agent to select an advisor, he might prefer his advisor to be as informed as possible. Therefore, the agent's preference order would coincide with the informedness order on the possible advisors. As a preference order is usually assumed to be a partial pre-order, one would like the same to hold for the informedness order (which includes satisfying transitivity).

⁵ To allow for easy reading, we abuse notation a bit and write for instance $C \rightarrow B \rightarrow A$ for the argumentation framework $(\{A, B, C\}, \{(C, B), (B, A)\})$.

discuss together, using the discussion games as for instance defined in [17]. The agent who is able to win the discussion is regarded to be more informed. In case the two agents agree on the status of the argument, then we look at what happens if a third agent comes in. If in every case where the first agent is able to convince the third agent, the second agent is also able to convince the third agent, then we say that the second agent is at least as informed as the first agent.

Definition 6. Let AF_1, \dots, AF_n be subargumentation frameworks of the UAF, where for each AF_i ($1 \leq i \leq n$) it holds that $AF_i = (Ar_i, att_i)$. We define a relation \preceq_{ds}^A (informedness based on discussed status) such that $AF_i \preceq_{ds}^A AF_j$ iff $A \in Ar_i \cap Ar_j$ and

- $JS_{AF_i}(A) \neq JS_{AF_j}(A)$ and agent j is able to win the relevant discussion game, based on each agent’s private argumentation framework, or
- $JS_{AF_i}(A) = JS_{AF_j}(A)$ and for each k that disagrees with this shared position, it holds that if agent i is able to win the relevant discussion from agent k then agent j is also able to win the relevant discussion from agent k .

With the “relevant discussion”, we mean the discussion in the sense of [17].

With this new definition, we do obtain sub-AF refinement (condition 1). This can be seen as follows. Suppose $AF_I \sqsubseteq AF_{II}$. We distinguish two cases.

- $JS_{AF_I}(A) \neq JS_{AF_{II}}(A)$. Then agent II has a winning strategy for defending his position on A (using the grounded and/or preferred games) which works when applied in AF_{II} . The fact that $AF_I \sqsubseteq AF_{II}$ means that agent I only knows a subset of counter moves that agent II has already taken into account in his winning strategy. Therefore, the winning strategy of agent II still works when playing against agent I.
- $JS_{AF_I}(A) = JS_{AF_{II}}(A)$. Now, assume the presence of agent III with argumentation framework AF_{III} (which is still a sub-AF of the UAF) who does not agree on the status of A . Then, if agent I has a winning strategy against agent III, then agent II is able to use the same winning strategy, because he knows a superset of possible arguments to move.

Apart from satisfying the sub-AF relation (condition 1), it can easily be verified that \preceq_{ds}^A also satisfies reflexivity (condition 2).

It can be interesting to see how \preceq_{ds}^A deals with the argumentation frameworks of Figure 1. Here, we have that $JS_{AF_I}(A) = \{\text{in}\}$ and $JS_{AF_{II}}(A) = \{\text{out}\}$. Let us examine what happens if these agents start to discuss (say, using the grounded game as described in [17]).

I: A has to be **in**

II: but maybe B does not have to be **out**

I: B has to be **out** because C has to be **in**

II: but maybe D does not have to be **out** (this is where agent I learns about D)

I: D has to be **out** because E has to be **in** (after learning about D , agent I realizes that E attacks D , since we assume that whenever an agent is aware of

two arguments (like E and D) the agent also knows whether there's an attack between them)

So here we see that agent I is able to win the discussion.

The example of Figure 4, however, is more complicated. Instead of AF_{II} having just one additional argument (as was the case in the example of Figure 1), it has three additional arguments. For most of the mainstream argumentation semantics, the outcome is not influenced when one substitutes a single argument by a chain of three arguments. The point, however, is that for the criterion of informedness based on discussed status, this substitution does matter. Whereas in the example of Figure 1 agent I is able to win the discussion, in the example of Figure 4 it is agent II who is able to win the discussion (this is because when agent II moves argument D , agent I is unable to respond, as he doesn't know about argument E , and hence loses the discussion).

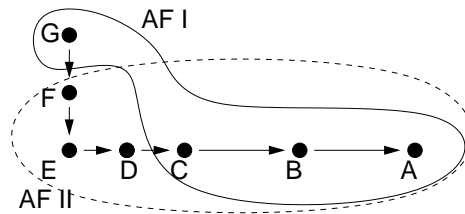

Fig. 4. Informedness based on discussed status can have unexpected results

Another issue that starts to play a role when one takes into account the possibility of dishonesty or strategic behaviour. An example of this is shown in Figure 5. Here, we have that initially agent I sincerely holds that the status of A has to be **out** ($JS_{AF_I}(A) = \{\text{out}\}$) whereas agent II sincerely holds that the status of A has to be **in** ($JS_{AF_{II}}(A) = \{\text{in}\}$). However, during the course of the discussion, agent I learns that his position does not hold, even though he can still successfully defend it. This discussion would look as follows.

II: A has to be **in**

I: but maybe B does not have to be **out**

II: B has to be **out** because C has to be **in** (this is where agent I learns about argument C)

I: but maybe D does not have to be **out** (this is where agent II learns about argument D and realizes that with this new information, A is no longer **in**)

II: D has to be **out** because E has to be **in** (agent II realizes that this is not the case, but utters this statement nevertheless, hoping that agent I does not know about argument F)

Since agent I cannot move any more (argument F is not in his argumentation framework), agent II wins the discussion.

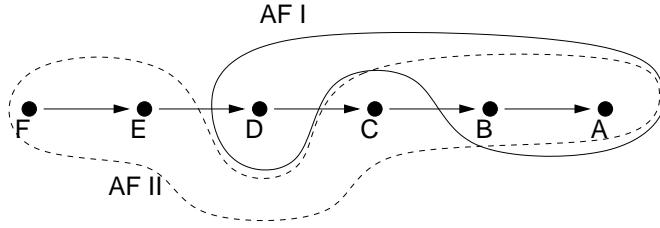

Fig. 5. Informedness based on discussed status and issues of dishonesty

Another problem is that although \preceq_{ds}^A satisfies sub-AF refinement (condition 1) and reflexivity (condition 2), it does not satisfy transitivity (condition 3). A counterexample is provided in Figure 6.

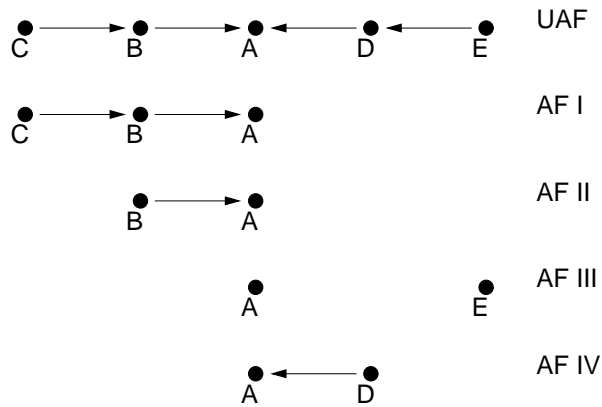

Fig. 6. Informedness based on discussed status can violate transitivity

In the example of Figure 6, agent I is more informed than agent II on argument A , because they disagree on the status of A and agent I is able to win the discussion. Agent II is more informed than agent III on argument A , because they disagree on the status of A and agent II is able to win the discussion. Transitivity would require that agent I is also more informed than agent III on argument A . However, this is not the case, because agents I and III agree on the status of A , but whereas agent III is able to win the discussion from agent IV, agent I is unable to win the discussion from agent IV. Therefore transitivity does not hold.

3.4 Comparing the different types of informedness

The three different types of informedness, as were introduced above, can be shown to be independent from each other.

Proposition 1. *The informedness relations \prec_{us} and \prec_{ms} are independent from each other. That is, $AF_i \prec_{us}^A AF_j$ does not imply $AF_i \prec_{ms}^A AF_j$ and vice versa.*

Proof. In Figure 1 it holds that $AF_I \prec_{us}^A AF_{II}$ but $AF_I \not\prec_{ms}^A AF_{II}$, hence providing a counter example against \prec_{us} being subsumed by \prec_{ms} . Also, it holds that $AF_{II} \prec_{ms}^A AF_I$ but $AF_{II} \not\prec_{us}^A AF_I$, hence providing a counter example against \prec_{ms} being subsumed by \prec_{us} .

Proposition 2. *The informedness relations \prec_{us} and \prec_{ds} are independent from each other. That is, $AF_i \prec_{us}^A AF_j$ does not imply $AF_i \prec_{ds}^A AF_j$ and vice versa.*

Proof. In Figure 1 it holds that $AF_I \prec_{us}^A AF_{II}$ but $AF_I \not\prec_{ds}^A AF_{II}$, hence providing a counter example against \prec_{us} being subsumed by \prec_{ds} . Also, it holds that $AF_{II} \prec_{ds}^A AF_I$ but $AF_{II} \not\prec_{us}^A AF_I$, hence providing a counter example against \prec_{ds} being subsumed by \prec_{us} .

Proposition 3. *The informedness relations \prec_{ms} and \prec_{ds} are independent from each other. That is, $AF_i \prec_{ms}^A AF_j$ does not imply $AF_i \prec_{ds}^A AF_j$ and vice versa.*

Proof. In Figure 4 it holds that $AF_{II} \prec_{ms}^A AF_I$ but $AF_{II} \not\prec_{ds}^A AF_I$, hence providing a counter example against \prec_{ms} being subsumed by \prec_{ds} . Also, it holds that $AF_I \prec_{ds}^A AF_{II}$ but $AF_I \not\prec_{ms}^A AF_{II}$, hence providing a counter example against \prec_{ds} being subsumed by \prec_{ms} .

4 Roundup

One of the key limitations of many of today's argumentation formalisms is that they are relatively static; they are not meant to be used in a context where new information comes in, especially when this is done using a dialectical process of two or more agents who are exchanging arguments. During such a discussion, agents can construct arguments based on private information that the other party does not necessarily possess, so these arguments can lead to belief changes at the side of the hearer. Sometimes, an agent can go on to defend a position that he no longer holds to be valid, due to the information that showed up during the course of the discussion, hoping to win the discussion nevertheless. Some of the relevant research questions appear to be the following:

- Is there a reasonable way of defining informedness which satisfies all three conditions, and performs well on the examples stated in the current paper?
- Given a particular way of defining informedness, what are the individual agents' best strategies for determining who is more informed. After all, the individual agents do not have full access to the UAF, or to the other agent's private AF. It seems most realistic that they try to test the other agent's informedness during some kind of discussion.

- To which extent is the way in which agents try to observe each other’s informedness strategy-proof? What are the optimal ways for a particular agent to appear to be more informed than he actually is? To what extent is (undetected) dishonesty possible?⁶

One particular issue is whether one wants to apply the complete justification status for determining the differences of opinion on a particular argument, or whether simpler approaches (such as membership of an admissible set, or membership of the grounded extension) would suffice. Another issue is whether there are more properties (other than condition 1, 2 and 3) that one would like to satisfy, and whether one can formalize the intuitions behind the examples in the current document in the form of postulates, in the same way as is for instance done in [6, 4].

References

1. P. Baroni, M.W.A. Caminada, and M. Giacomin. An introduction to argumentation semantics. *Knowledge Engineering Review*, 26(4):365–410, 2011.
2. P. Baroni and M. Giacomin. On principle-based evaluation of extension-based argumentation semantics. *Artificial Intelligence*, 171(10-15):675–700, 2007.
3. Ph. Besnard and A. Hunter. Constructing argument graphs with deductive arguments: A tutorial. *Argument & Computation*, 5:5–30, 2014. Special Issue: Tutorials on Structured Argumentation.
4. R. Booth, M.W.A. Caminada, M. Podlaszewski, and I. Rahwan. Quantifying disagreement in argument-based reasoning. In *Proceedings of the 11th international conference on autonomous agents and multiagent systems*, 2012.
5. M.W.A. Caminada. On the issue of reinstatement in argumentation. In M. Fischer, W. van der Hoek, B. Konev, and A. Lisitsa, editors, *Logics in Artificial Intelligence; 10th European Conference, JELIA 2006*, pages 111–123. Springer, 2006. LNAI 4160.
6. M.W.A. Caminada and L. Amgoud. On the evaluation of argumentation formalisms. *Artificial Intelligence*, 171(5-6):286–310, 2007.
7. M.W.A. Caminada, W. Dvořák, and S. Vesic. Preferred semantics as socratic discussion. *Journal of Logic and Computation*, 2014. (in print).
8. M.W.A. Caminada and D.M. Gabbay. A logical account of formal argumentation. *Studia Logica*, 93(2-3):109–145, 2009. Special issue: new ideas in argumentation theory.
9. M.W.A. Caminada and G. Pigozzi. On judgment aggregation in abstract argumentation. *Journal of Autonomous Agents and Multi-Agent Systems*, 2009.

⁶ For instance, Sakama et al. [10, 11] provide a formal account of various forms of dishonesty. Their analysis includes Harry Frankfurt’s notion of *bullshit* [15], which consists of making claims of which one has no proper knowledge or beliefs. However, their analysis is done in terms of traditional (truth based) multi-modal logic. An open question, therefore, is how to provide an alternative formalisation of this form of dishonesty, one that is not based on truth of belief, but on the notion of argument-based informedness.

10. M.W.A. Caminada Ch. Sakama and A. Herzig. A logical account of lying. In Tomi Janhunen and Ilkka Niemelä, editors, *Proceedings of the 12th European Conference on Logics in Artificial Intelligence (JELIA)*, volume 6341 of *Lecture Notes in Artificial Intelligence*, pages 286–299. Springer Berlin / Heidelberg, 2010.
11. M.W.A. Caminada Ch. Sakama and A. Herzig. A formal account of dishonesty. *Logic Journal of the IGPL*, 23:259–294, 2015.
12. P.M. Dung. On the acceptability of arguments and its fundamental role in non-monotonic reasoning, logic programming and n -person games. *Artificial Intelligence*, 77:321–357, 1995.
13. W. Dvořák. On the complexity of computing the justification status of an argument. In Sanjay Modgil, Nir Oren, and Francesca Toni, editors, *Theorie and Applications of Formal Argumentation*, Lecture Notes in Computer Science, pages 32–49. Springer, 2012.
14. M. Fitting. Bilattices and the semantics of logic programming. *J. Logic Programming*, 11:91–116, 1991.
15. Harry G. Frankfurt. *On Bullshit*. Princeton University Press, 2005.
16. G. Governatori, M.J. Maher, G. Antoniou, and D. Billington. Argumentation semantics for defeasible logic. *Journal of Logic and Computation*, 14(5):675–702, 2004.
17. S. Modgil and M.W.A. Caminada. Proof theories and algorithms for abstract argumentation frameworks. In I. Rahwan and G.R. Simari, editors, *Argumentation in Artificial Intelligence*, pages 105–129. Springer, 2009.
18. S. Modgil and H. Prakken. The ASPIC+ framework for structured argumentation: a tutorial. *Argument & Computation*, 5:31–62, 2014. Special Issue: Tutorials on Structured Argumentation.
19. H. Prakken. An abstract framework for argumentation with structured arguments. *Argument and Computation*, 1(2):93–124, 2010.
20. C. Sakama. Ordering default theories. *Theoretical Computer Science*, 338:127–152, 2005.
21. F. Toni. A tutorial on assumption-based argumentation. *Argument & Computation*, 5:89–117, 2014. Special Issue: Tutorials on Structured Argumentation.
22. Y. Wu and M.W.A. Caminada. A labelling-based justification status of arguments. *Studies in Logic*, 3(4):12–29, 2010.
23. Y. Wu, M.W.A. Caminada, and D.M. Gabbay. Complete extensions in argumentation coincide with 3-valued stable models in logic programming. *Studia Logica*, 93(1-2):383–403, 2009. Special issue: new ideas in argumentation theory.